

FLAT PANEL MOBILE STAND (OPT-MS-103)

SPECIFICATIONS

Compatibility : 32" to 42" Flat Panel
 Maximum load : 55 KG (121 lbs)
 Color : Black
 Tilting Angle : 0 to +20 degree

KEY FEATURES

- Aluminium Extrusion Pole
- Inter-changeable front plate for different size of TV.
- Great Mobility
- Great flexibility and adaptability
- Fast disconnection for ease of maintenance
- Hardware included
- Integrated Cable Management
- "Clip-On" locking device



DRAWINGS & DIMENSIONS

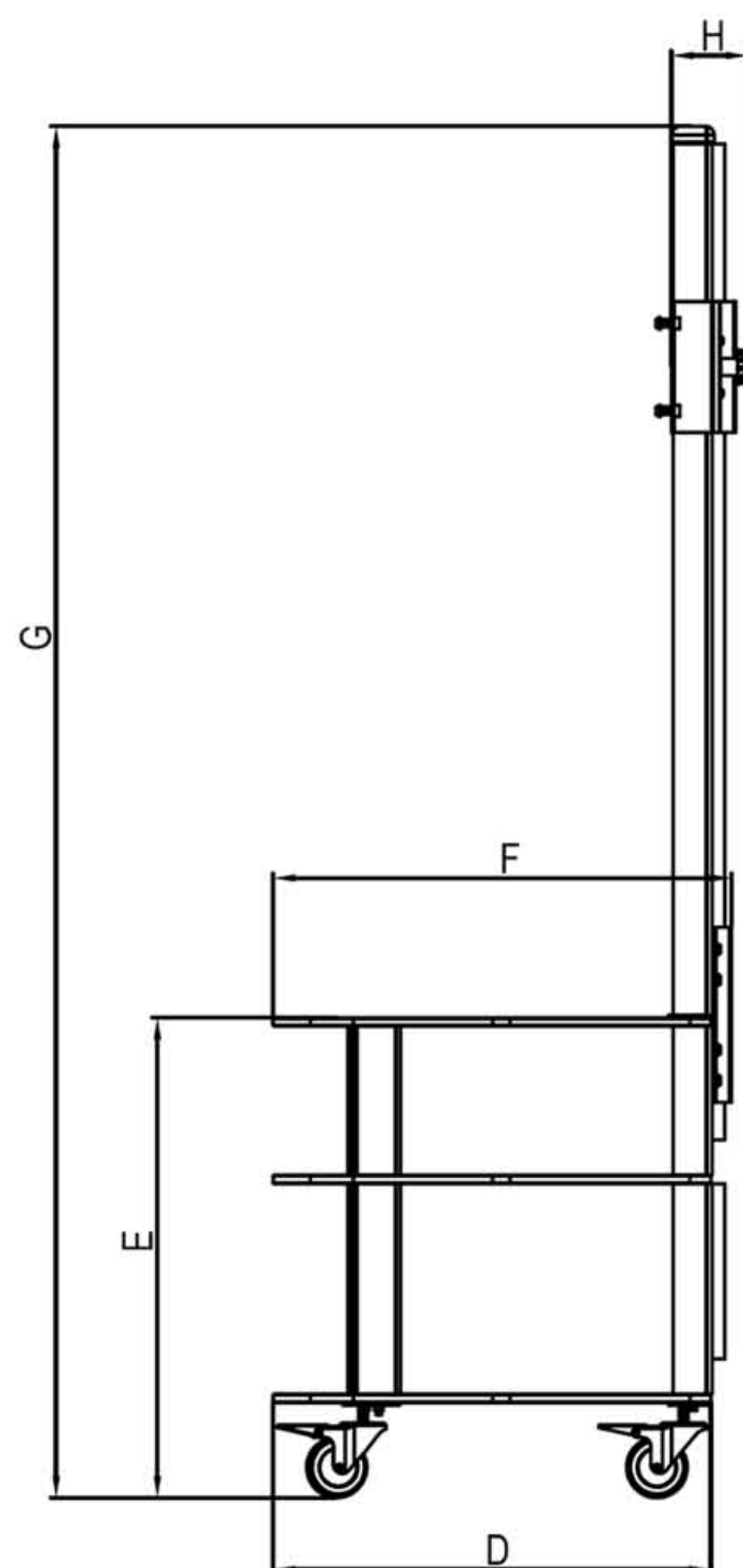
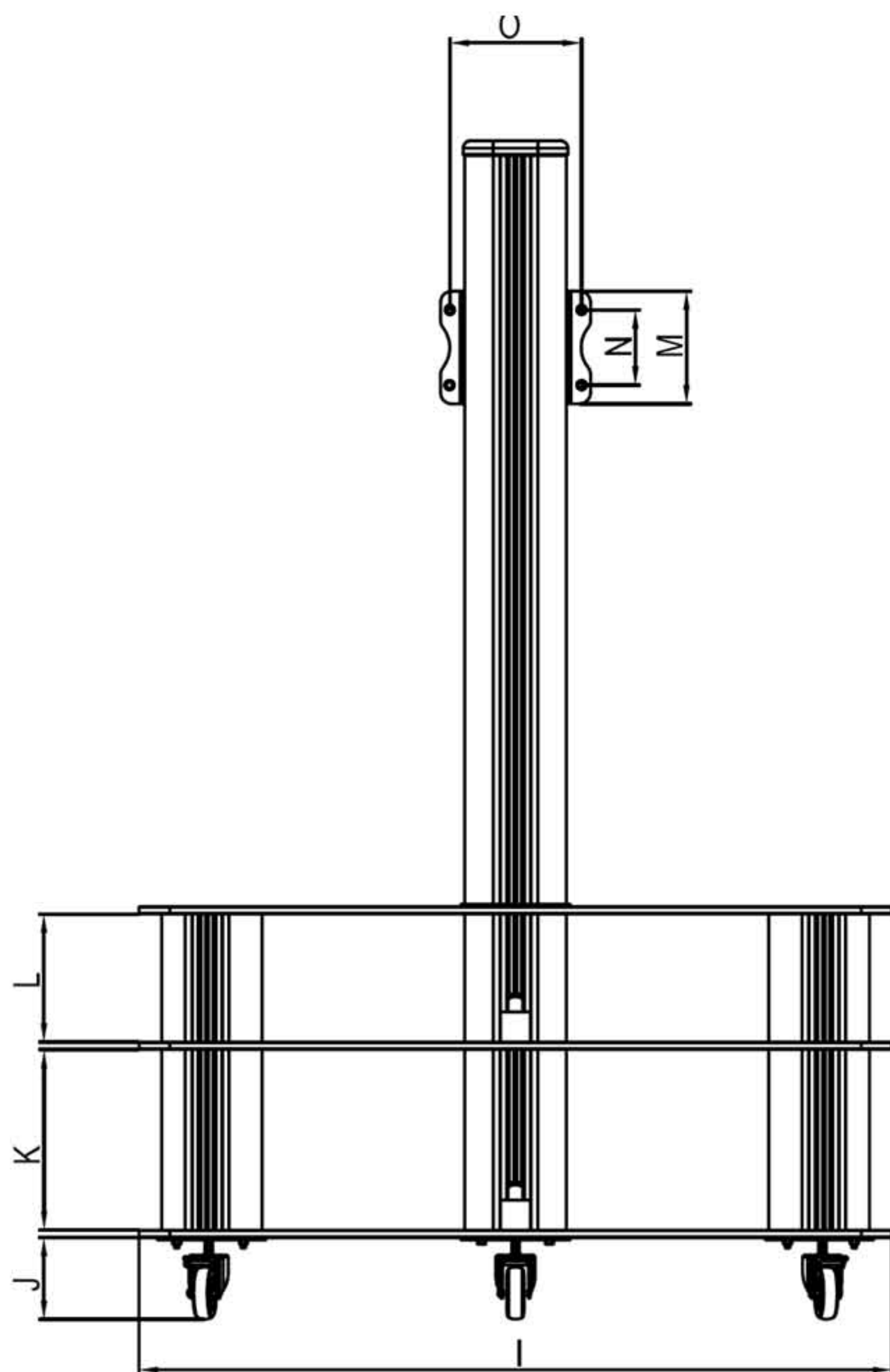

DIMENSIONS

A	39.37"	1000.00mm
B	19.68"	500.00mm
C	21.33"	542.00mm
D	19.68"	500.00mm
E	21.61"	549.00mm
F	20.59"	523.00mm
G	61.69"	1567.00mm
H	3.42"	87.00mm
I	39.37"	1000.00
J	4.29"	109.00mm
K	9.44"	240.00mm
L	4.29"	109.00mm
M	5.90"	150.00mm
N	3.93"	100.00mm
O	6.88"	175.00mm

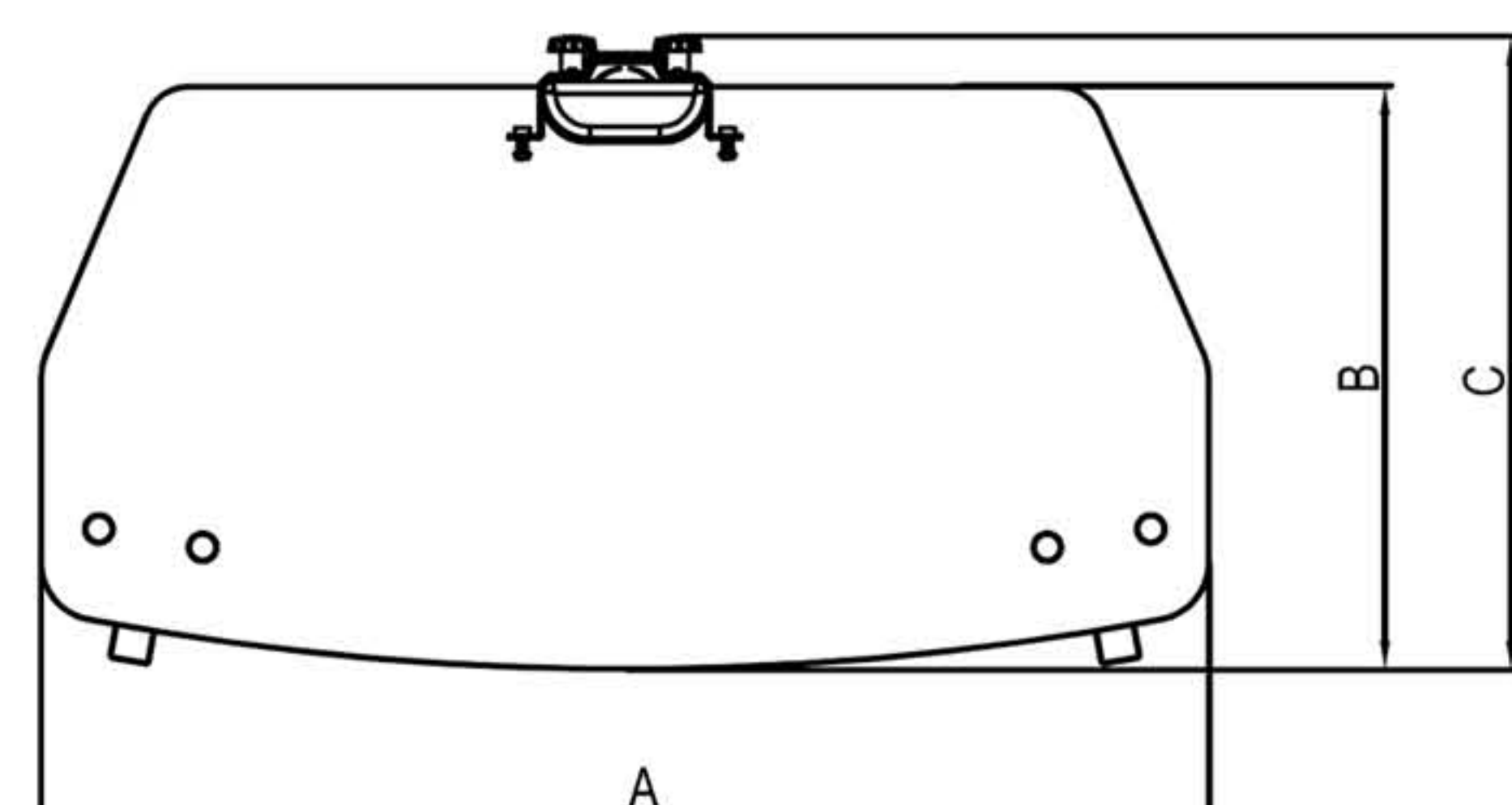

(OPT-MS-103)

SPECIFICATIONS



100KG (220LBS)

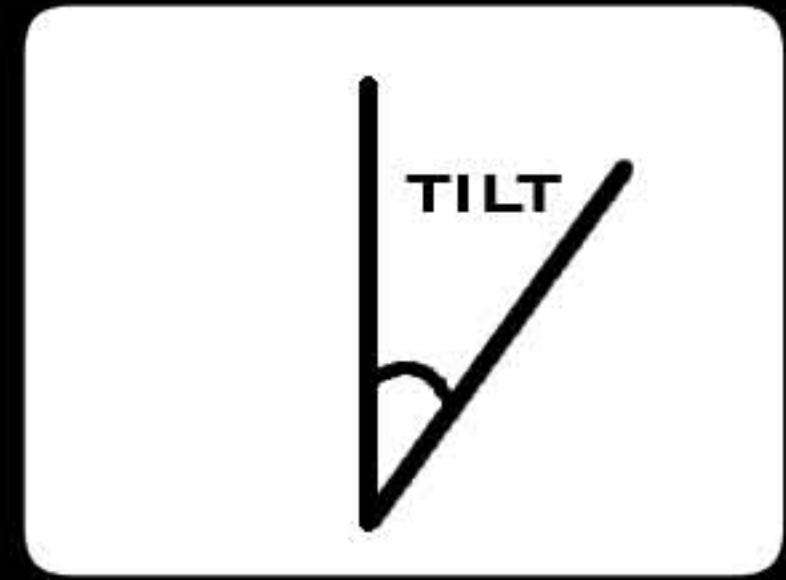

0 TO +20 DEGREE

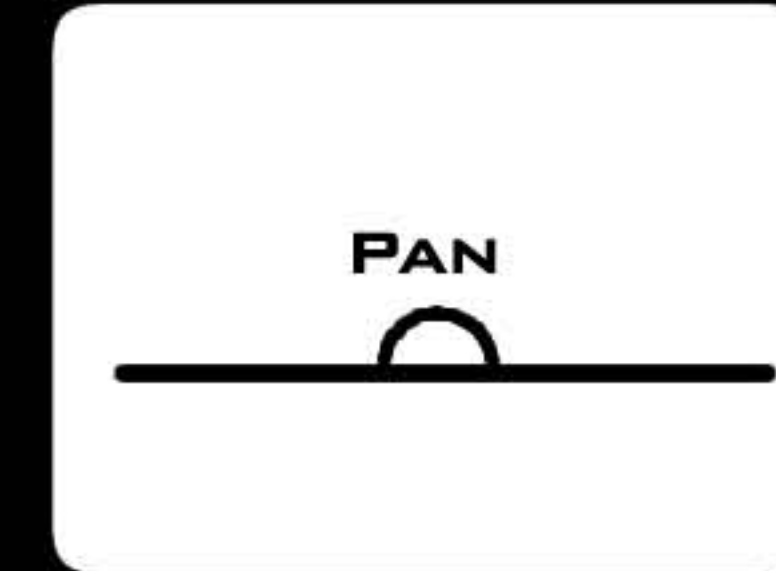

N.A

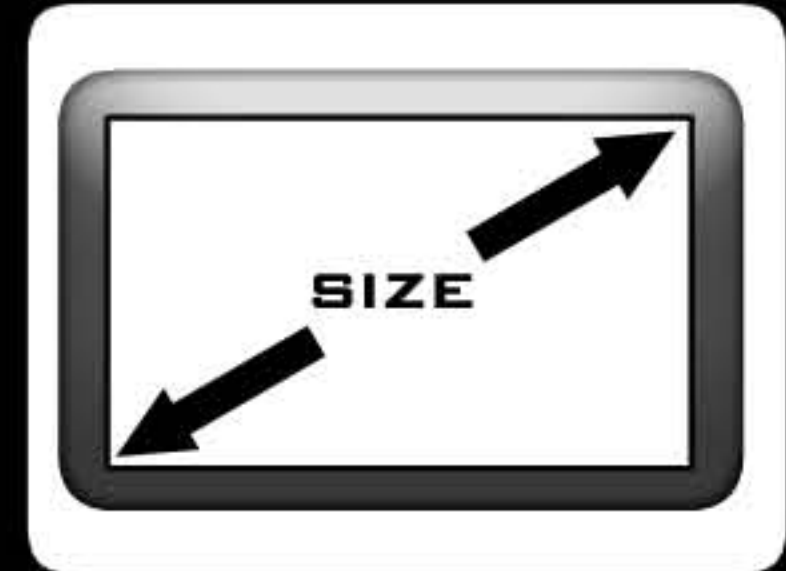

37" TO 50"

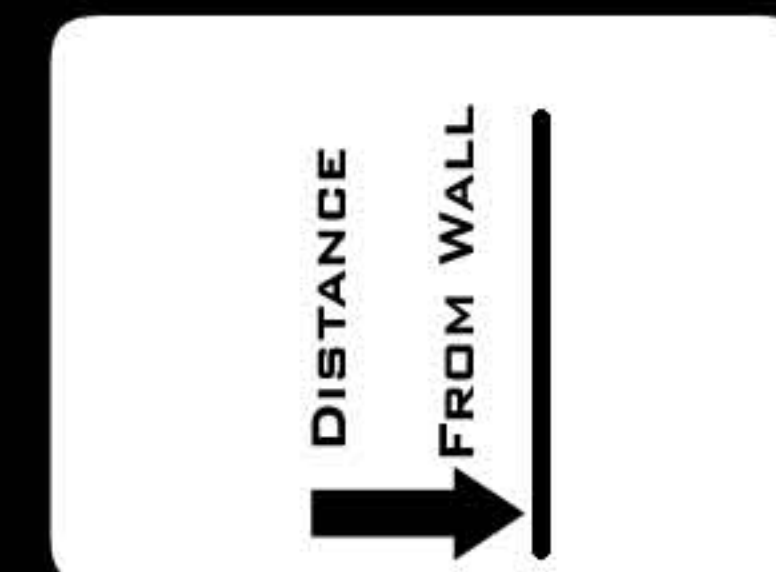

N.A

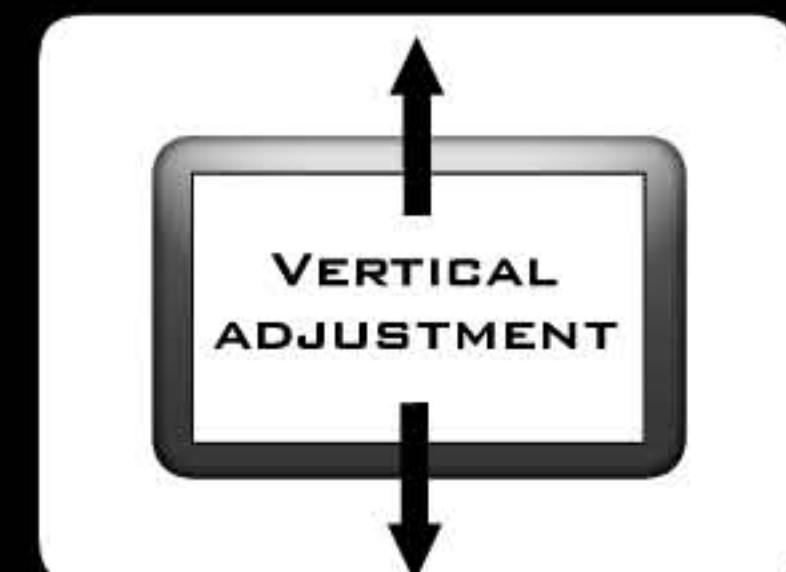

ENTIRE POLE

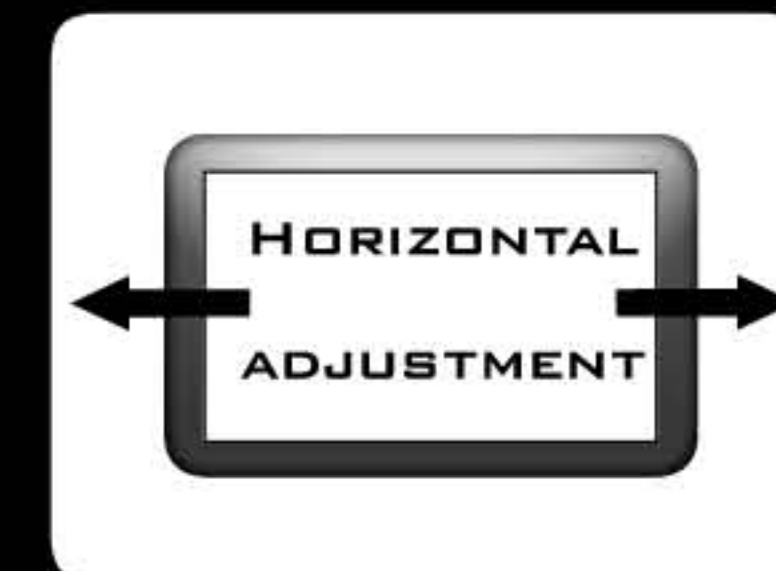

AVAILABLE

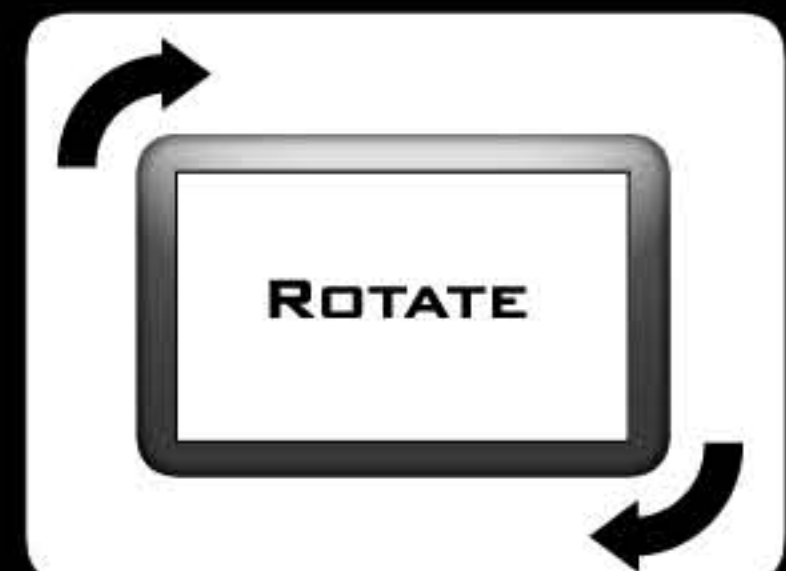

N.A

VESA STANDARD
 75 x 75
 100 x 100
 200 x 100
 200 x 200
 400 x 200
 600 x 400
 800 x 400



HIGH-LIGHTED

BLACK / SILVER

HARDWARE

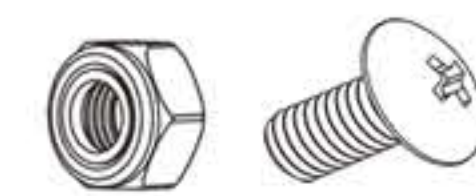

CABLE MANAGEMENT

INCLUDED

AVAILABLE

For General Information & Sales Enquires

OPTVIO PTE LTD

Block 20, Woodlands Link #08 - 11
 Woodlands East Industrial Estate
 Singapore 738733

Website: www.optvio.com
 Tel : (65) 62572029
 Fax : (65) 62575829



PRODUCT OF SINGAPORE